

WORKING VOLUME: 13635L
 TOTAL VOLUME: 16750L

CONCRETE: 35 MPa WITH 5-8% AIR ENTRAINMENT
 NON-SULPHATE RESISTANT

REINFORCING: WALLS, FLOOR, AND LID
 D9.5 HIGH TENSILE STEEL MAT W/MIN 38mm COVER
 150MM O/C E/W
 OR
 10M@ 200mm O/C E/W
 10M BAR DIAGONALS AT EACH CORNER OF LID OPENINGS

WEIGHT TOP SECTION 4700 KGS
 BOTTOM SECTION 10575 KGS
 TOTAL 15275 KGS

MAXIMUM BURIAL DEPTH: 1200mm (48")

WATER TIGHTNESS: CON-SEAL CS-102 MASTIC SEALANT
 BETWEEN PIECES. SEALANT APPLIED ONSITE BY BOYD BROS
 CONCRETE ACCORDING TO MANUFACTURER'S
 RECOMMENDED METHOD.

PIPE/WALL CONNECTIONS: POLYLOK IV 100mm HIGH PRESSURE SEAL CAST
 IN CONCRETE

ACCESS OPENINGS: TUF-TITE 24x6 RISER AND LID. ADDITIONAL RISERS
 AVAILABLE. OPSD AND PUMP ACCESS LIDS AVAILABLE.

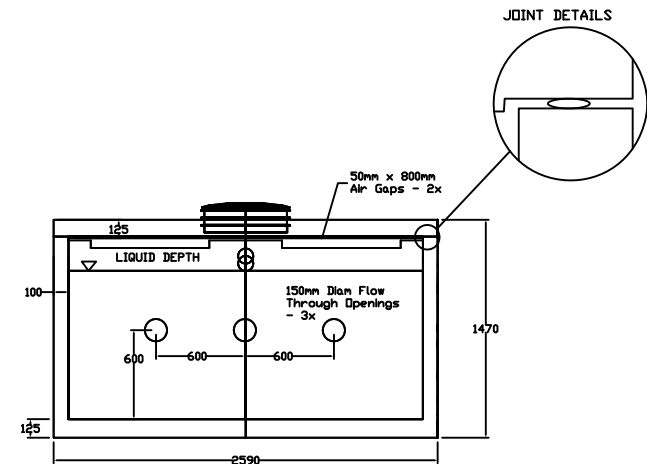
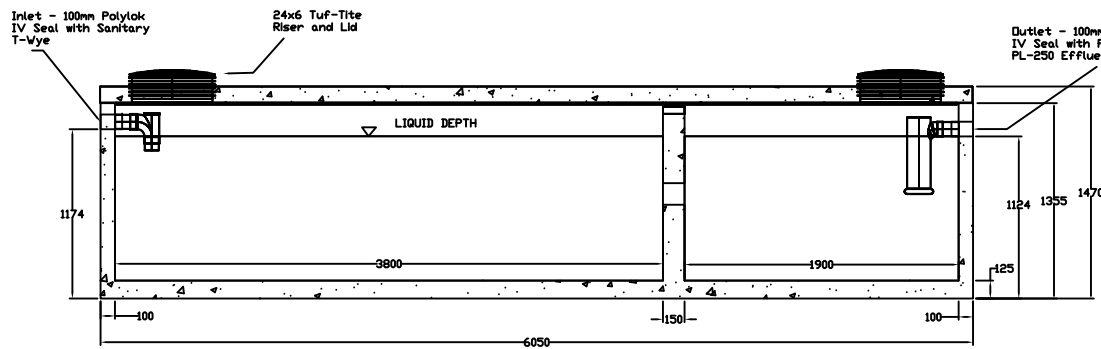

BOYD BROTHERS
 5450 CUDDY ST, OSGOODE, ONT, K0A 2W0
 tel (613) 826-2318 fax (613) 826-3679
 toll free 888-846-6664
 website www.boydbrosconcrete.ca
 e-mail info@boydbrosconcrete.ca

PRODUCT
13625L 2-COMPARTMENT SEPTIC TANK

SERIES NO	13.6	MODEL NO	13.6	MODELS IN SERIES	12.6, 13.6, 18, 23, 27, 30, 35
SCALE	1:1250	REV	1.0	DATE	OCT 19, 2017