

WORKING VOLUME: 3200 LITRES (700 GAL)
 CONCRETE: 32 MPa WITH 5-8% AIR ENTRAINMENT
 NON-SULPHATE RESISTANT

REINFORCEMENT: BAR MEETS OR EXCEEDS CSA A23.4
 WEIGHT: TOP SECTION - 850 Kg (1900 lbs)
 BOTTOM SECTION - 3120 Kg (7000 lbs)
 TOTAL - 3970Kg (8900 lbs)

MAXIMUM BURIAL DEPTH: 600mm (24") EARTH COVER - NON-VEHICULAR TRAFFIC

WATER TIGHTNESS: CON-SEAL CS-102 MASTIC SEALANT BETWEEN LID AND BOTTOM SECTION APPLIED IN FACTORY ACCORDING TO MANUFACTURER'S RECOMMENDED METHOD.

PIPE / WALL CONNECTIONS:

INLET: 100mm (4") POLYLOK IV HIGH PRESSURE SEAL CAST IN CONCRETE WITH BAFFLE INSTALLED.
 OUTLET: 100mm (4") POLYLOK IV HIGH PRESSURE SEAL CAST IN CONCRETE WITH BAFFLE INSTALLED.
 PRIMARY AND SECONDARY SEPARATION BAFFLES EXTEND VERTICALLY TO 150mm FROM FLOOR
 TERTIARY SEPARATION BAFFLE EXTENDS VERTICALLY TO 100mm FROM FLOOR.

TANK BODY AND LID LIFTED USING BOYD BROTHERS LTD SUPPLIED RIGGING.

TUF-TITE 6" X 20" RISERS CAST IN CONCRETE. ADDITIONAL GRADE RINGS AVAILABLE.
 CAST-IRON GRATES AND ADDITIONAL REINFORCING FOR DEEPER BURIAL OPTIONAL.

CONFORMS TO CSA STANDARD B66-10

INLET - 100mm (4") POLYLOK IV SEAL WITH OPEN-TOPPED SANITARY T-Y BAFFLE

OUTLET - 100mm (4") POLYLOK IV RUBBER SEAL

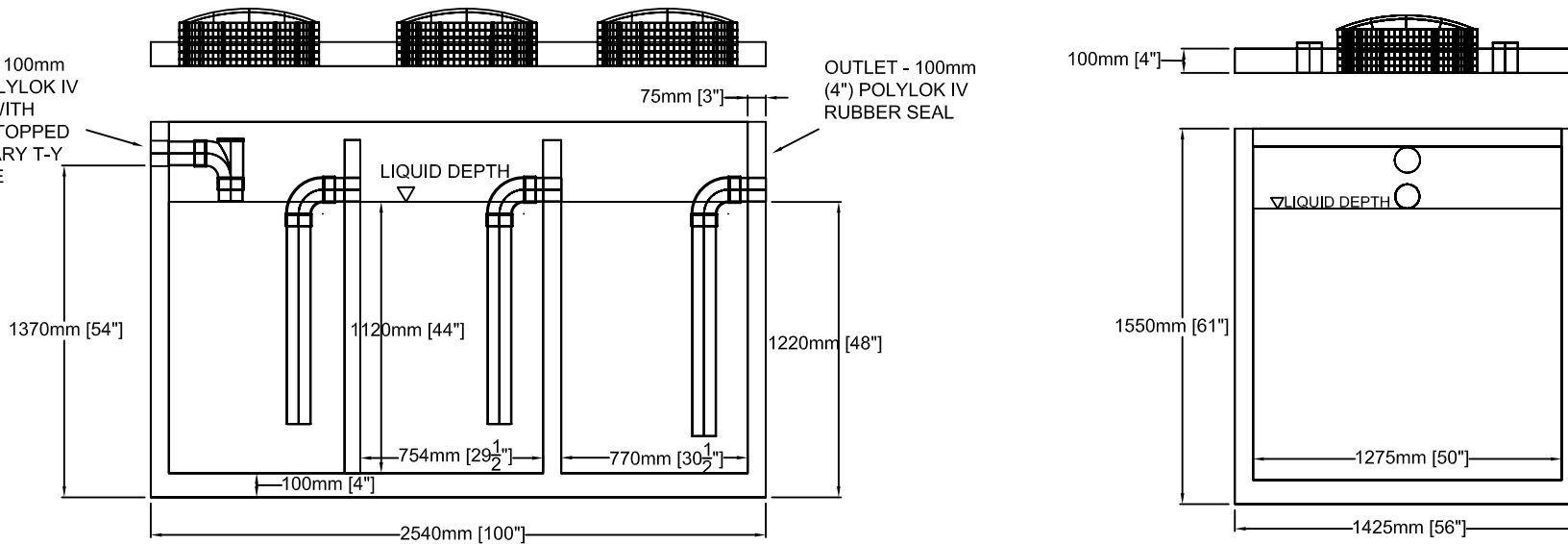

BOYD BROTHERS

5450 CUDDY ST, OSGOODE, ONT, K0A 2W0
 tel (613) 826-2318 fax (613) 826-3679
 toll free 888-846-6664
 website www.boydbrosconcrete.ca
 e-mail info@boydbrosconcrete.ca

PRODUCT		
3200L (700 GAL) OIL SEPARATOR TANK		
SERIES NO	MODEL NO	MODELS IN SERIES
3600	3200OIL	3600R, 3200OIL
SCALE	REV	DATE
1:30	1.0	FEBRUARY 28, 2013