

WORKING VOLUME to liquid depth: 3600L (800 GAL)
 TOTAL VOLUME to underside of lid: 4500L (1000 GAL)

CONCRETE: 32MPa @ 28 DAYS WITH 5-8% AIR-ENTRAINMENT
 NON-SULPHATE RESISTANT

REINFORCEMENT: 10M DEFORMED BAR W/MIN 25mm (1") COVER
 WALLS AND BASE @ Vertical - 550mm from corner EW
 Horizontal - 50mm and 600mm from top and around corner
 LID @ 600mm O/C EW

WEIGHT TANK BODY: 3150 KG (7,050 LBS)
 LID: 1125 KG (2,520 LBS)
 TOTAL: 4275 KG (9,570 LBS)

BURIAL DEPTH: 600mm (24") MAXIMUM EARTH COVER - NON-VEHICULAR TRAFFIC

WATER TIGHTNESS: CON-SEAL CS-102 MASTIC SEALANT BETWEEN LID AND BOTTOM SECTION
 APPLIED IN FACTORY ACCORDING TO MANUFACTURER'S RECOMMENDED METHOD

CENTRE WALL MONOLITHIC WITH TANK BODY

PIPE/WALL CONNECTIONS:
 INLET - POLYLOK IV HIGH PRESSURE SEAL CAST IN CONCRETE FITTED WITH 100mm (4") OPEN-TOPPED TEE BAFFLE EXTENDING INTO LIQUID LEVEL 100mm (4").
 OUTLET - POLYLOK IV HIGH PRESSURE SEAL CAST IN CONCRETE FITTED WITH TUF-TITE EF-6 EFFLUENT FILTER (1.6mm (1/16") FILTRATION) EXTENDING INTO LIQUID LEVEL 400mm (16")

ACCESS OPENINGS: TUF-TITE 600mm \varnothing ACCESS RISERS AND LID CAST IN CONCRETE. LID SECURED WITH STAINLESS STEEL HARDWARE. LID EXTENDS 150mm ABOVE TOP OF TANK. ADDITIONAL RISERS CAN BE ADDED TO BRING ACCESS TO GRADE.

TANK BODY AND LID LIFTED USING BOYD BROTHERS LTD SUPPLIED RIGGING

CONFORMS TO CSA STANDARD B66-10

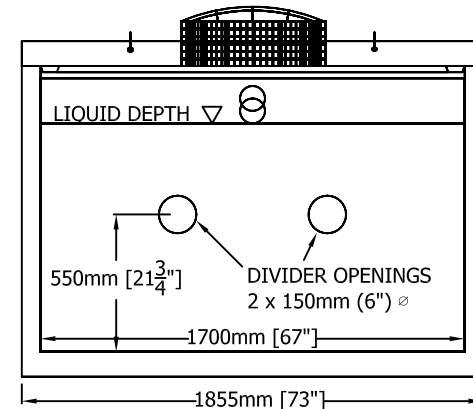
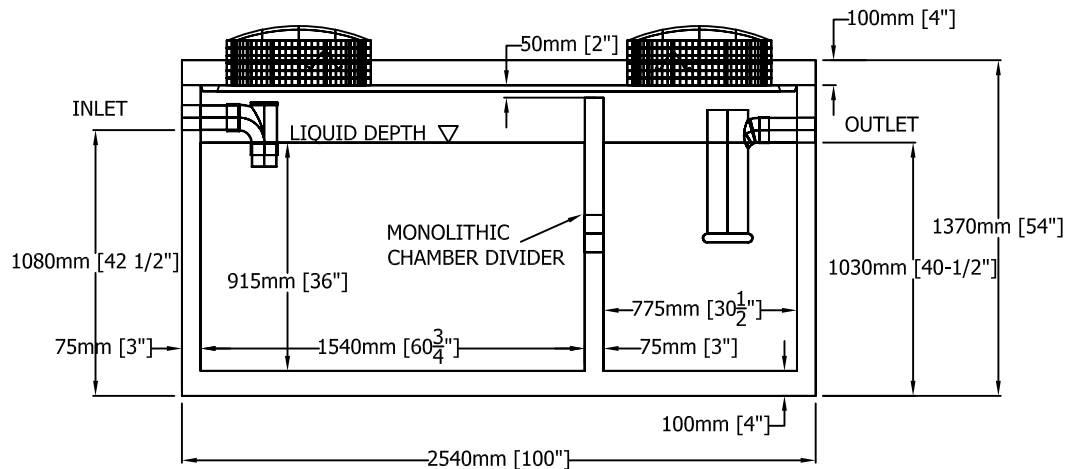

BOYD BROTHERS
 5450 CUDDY ST, OSGOODE, ONT, K0A 2W0
 tel (613) 826-2318 fax (613) 826-3679
 toll free 888-846-6664
 website www.boydbrosconcrete.ca
 e-mail info@boydbrosconcrete.ca

PRODUCT		
3600L (800 GAL) LOW-PROFILE SEPTIC TANK		
SERIES NO	MODEL NO	MODELS IN SERIES
3600L	3600L	4800R, 3600L, 3200oil
SCALE	REV	DATE
1:30	1.0	MAY 22, 2015