

WORKING VOLUME: 7200 LITRES (1600 GAL)
 TOTAL VOLUME: 8850 LITRES (1950 GAL)
 CONCRETE: 32 MPa WITH 5-8% AIR ENTRAINMENT
 NON-SULPHATE RESISTANT
 REINFORCING: 10M DEFORMED BAR W/ MIN 25mm (1") COVER
 WALLS AND BASE @ 375mm O/C EW
 LID @ 375mm O/C EW AND ADDITIONAL RING AT RIBS
 SLIP-IN DIVIDER @ 600mm O/C EW

WEIGHT: TOP SECTION - 2775 Kg (6120 lbs)
 BOTTOM SECTION W/ DIV - 5310 Kg (11900 lbs)
 TOTAL - 8085 Kg (18110 lbs)

MAXIMUM BURIAL DEPTH: 600mm (24")

WATER TIGHTNESS: CON-SEAL CS-102 MASTIC SEALANT BETWEEN LID AND BOTTOM SECTION APPLIED ON-SITE BY BOYD BROTHERS LTD. ACCORDING TO MANUFACTURER'S RECOMMENDED METHOD CENTRE WALL CAST SEPARATELY.

PIPE / WALL CONNECTIONS:
 INLET/OUTLET: POLYLOK IV HIGH PRESSURE SEAL CAST IN CONCRETE.
 INLET: 100mm SANITARY TEE BAFFLE. BAFFLE TO EXTEND 100mm BELOW LIQUID.
 OUTLET: EFFLUENT FILTER INSTALLED. OPEN-TOPPED EFFLUENT FILTER EXTENDS 400mm BELOW LIQUID AND TO AT LEAST THE TOP OF CHAMBER DIVIDER WITH 25mm MIN. AIR SPACE.

TUF-TITE 6" X 20" RISERS CAST IN CONCRETE FOR ACCESS. 24" DIAMETER RISERS OPTIONAL.

TANK BODY LIFTED USING A SLING

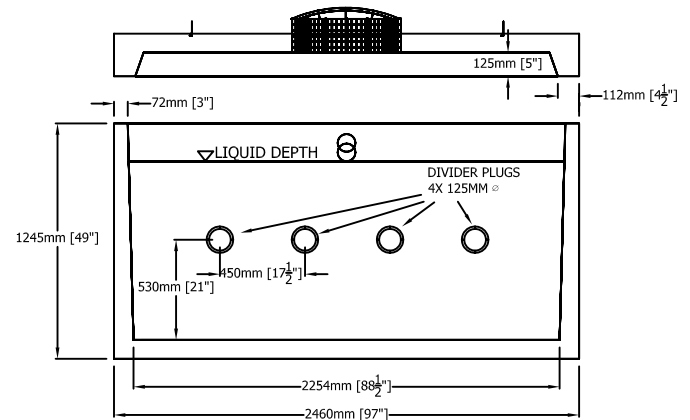
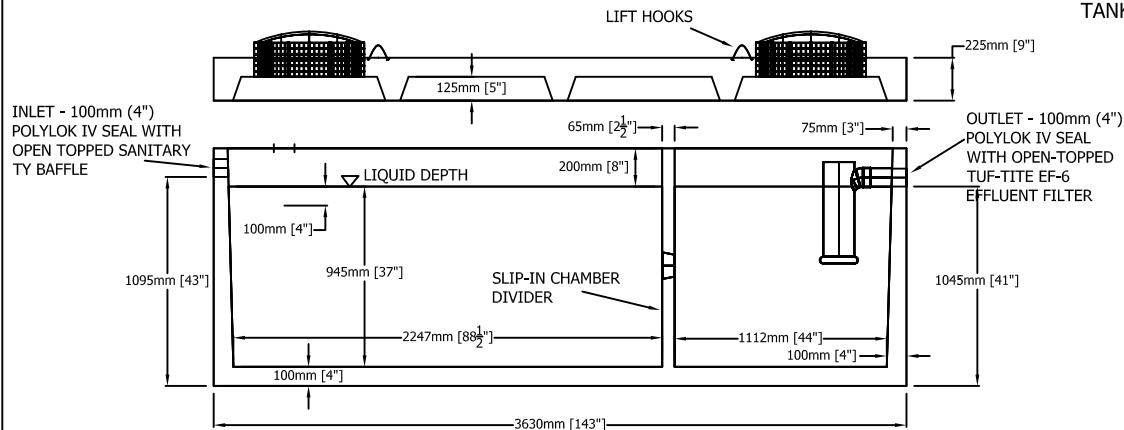

BOYD BROTHERS
 5450 CUDDY ST
 OSGOODE, ONT, K0A 2W0
 tel (613) 826-2318
 fax (613) 826-3679
 toll free 888-846-6664

PRODUCT		
7200L (1600 GAL) LOW-BOY SEPTIC TANK		
SERIES NO	MODEL NO	MODELS IN SERIES
9400	7200LB	9400R, 7700R, 7200LB
SCALE	REV	DATE
1:40	6.0	NOVEMBER 17, 2014