

WORKING VOLUME: 9400 LITRES (2070 GAL)
 TOTAL VOLUME: 11000 LITRES (2420 GAL)

CONCRETE: 32 MPa WITH 5-8% AIR ENTRAINMENT
 NON-SULPHATE RESISTANT

REINFORCING: 10M DEFORMED BAR W/ MIN 25mm (1") COVER
 WALLS AND BASE @ 600mm O/C EW
 LID @ 375mm O/C EW
 SLIP-IN DIVIDER @ 600mm O/C EW

WEIGHT: TOP SECTION - 2775 Kg (6120 lbs)
 BOTTOM SECTION W/ DIV - 5940 Kg (13305 lbs)
 TOTAL - 8715 Kg (19425 lbs)

MAXIMUM BURIAL DEPTH: 1200mm (48")

WATER TIGHTNESS: CON-SEAL CS-102 MASTIC SEALANT BETWEEN LID
 AND BOTTOM SECTION APPLIED ON-SITE BY BOYD BROTHERS LTD.
 ACCORDING TO MANUFACTURER'S RECOMMENDED METHOD

CENTRE WALL CAST SEPARATELY.

PIPE / WALL CONNECTIONS:

INLET: POLYLOK IV HIGH PRESSURE SEAL CAST IN CONCRETE WITH INLET
 BAFFLE INSTALLED. BAFFLE EXTENDS 100mm BELOW LIQUID.

OUTLET: POLYLOK IV HIGH PRESSURE SEAL CAST IN CONCRETE WITH
 EFFLUENT FILTER INSTALLED. OPEN-TOPPED EFFLUENT FILTER EXTENDS
 400mm BELOW LIQUID AND TO AT LEAST THE TOP OF CHAMBER DIVIDER WITH
 25mm MIN. AIR SPACE.

TUF-TITE 6" X 20" RISERS CAST IN CONCRETE FOR ACCESS.

TANK BODY LIFTED USING A SLING

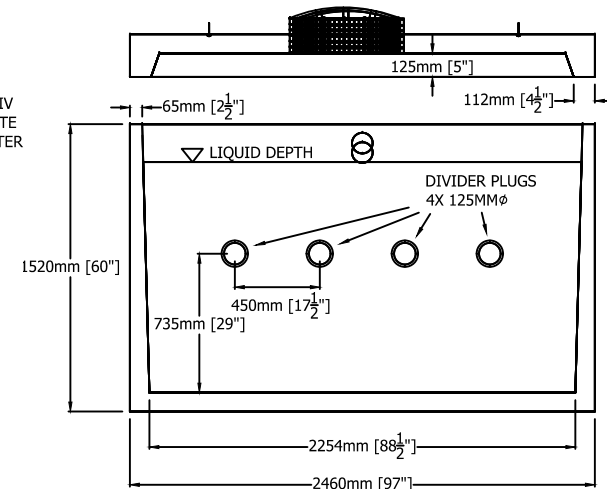
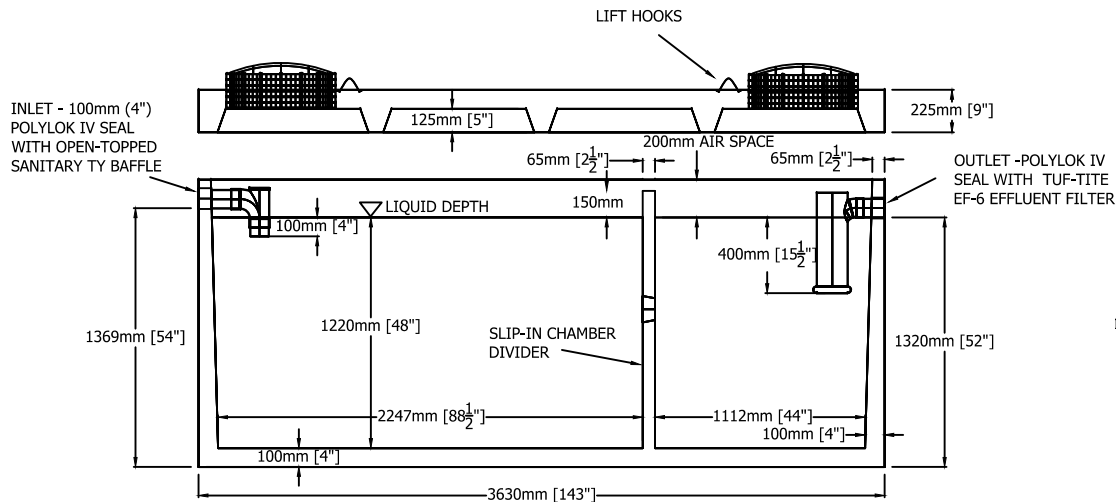

bb **BOYD BROS**
 concrete products

BOYD BROTHERS

5450 CUDDY ST, OSGOODE, ONT, K0A 2W0
 tel (613) 826-2318 fax (613) 826-3679
 toll free 888-846-6664
 website www.boydbrosconcrete.ca
 e-mail info@boydbrosconcrete.ca

PRODUCT
9400L (2070 GAL) REGULAR SEPTIC TANK

SERIES NO	9400	MODEL NO	9400R	MODELS IN SERIES	9400R, 7700R, 7200LB
SCALE	1:40	REV	7.0	DATE	MAY 29, 2014