

HIGH CAPACITY FENCE LINE BUNK

High Strength 32 MPa Air-Entrained Concrete
 Meets CFBA Concrete Guidelines for Severe Manure Gases Exposure C-2
 Each unit weighs 900kg (2000lbs)
 1/2" Holes cast in side of bunk to attach headrails
 End pieces available
 Forklift slots enable easy relocation

Steel Posts and Cable Rails Available

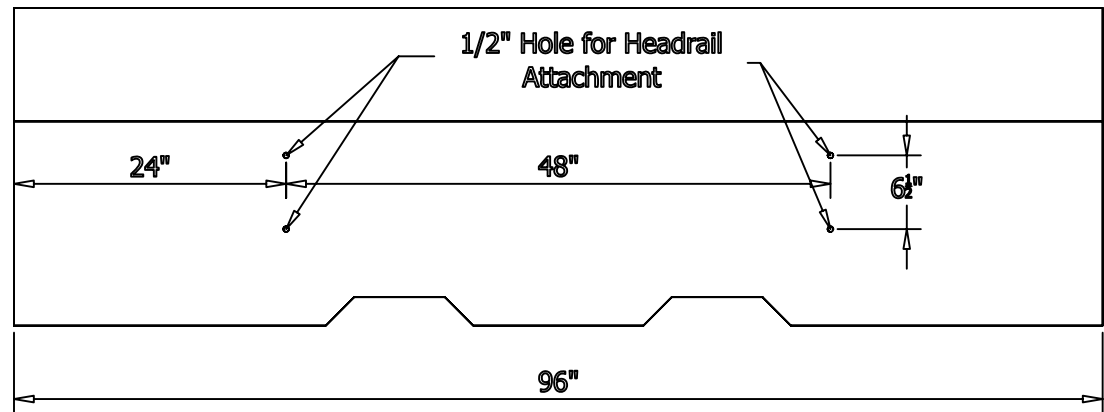
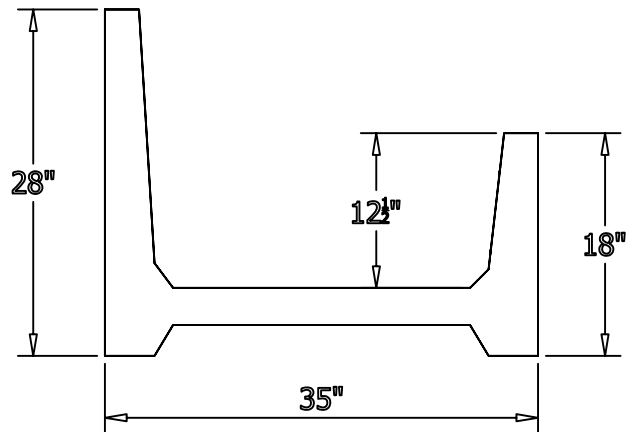
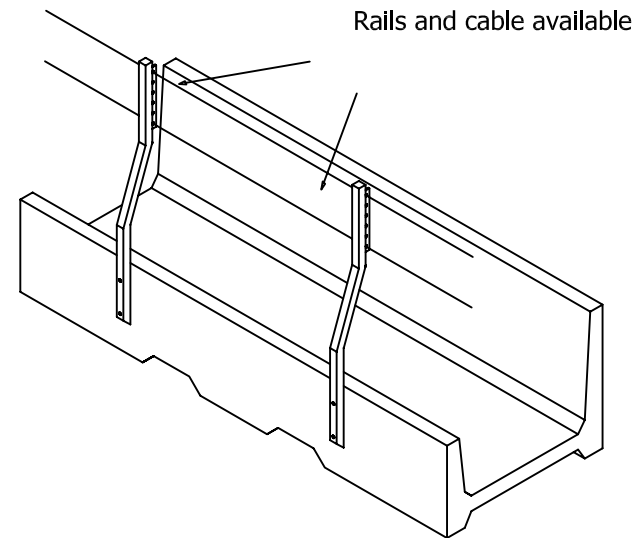

BOYD BROTHERS

5450 CUDDY ST
 OSGOODE, ONT, K0A 2W0
 tel (613) 826-2318
 fax (613) 826-3679
 toll free 888-846-6664

PRODUCT		
HIGH CAPACITY FENCE LINE FEEDBUNK		
SERIES NO	MODEL NO	MODELS IN SERIES
FEED BUNK	FENCE LINE	FENCE LINE
SCALE	REV	DATE
1:X	1.0	JUNE 25, 2006