

4

3

2

1

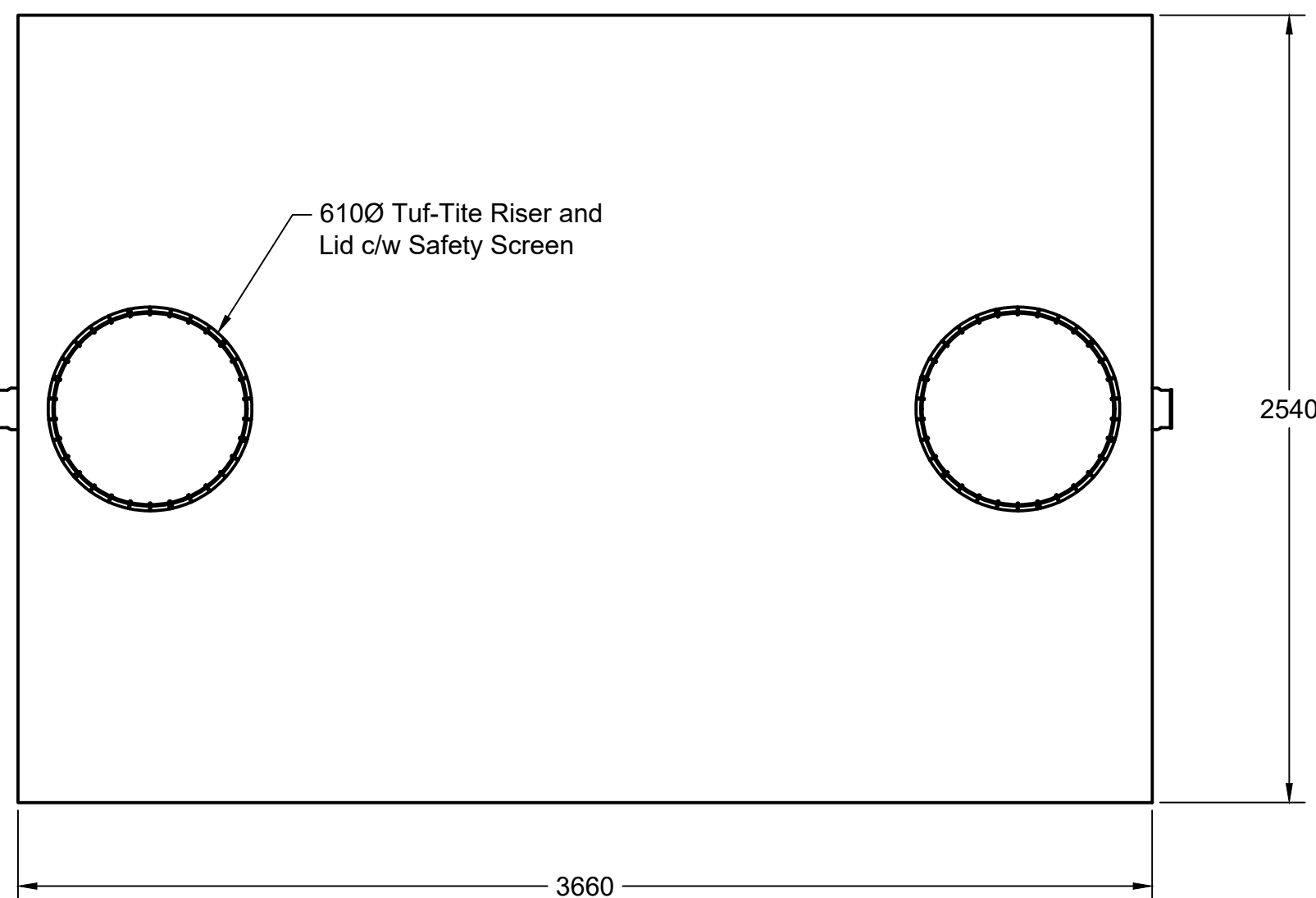

WORKING VOLUME: 12260L
 TOTAL VOLUME: 14120L

CONCRETE:
 35MPa w/ 5-8% Air Entrainment
 Non-sulphate resistant

REINFORCING:
 Each Section - 10M bar at 450mm O/C E/W

WEIGHT:
 TOP SECTION: 4500kgs
 BOTTOM SECTION: 4500kgs

MAX BURIAL DEPTH: 1200mm

WATER TIGHTNESS:
 1x row ConSeal CS102-1.25" Butyl mastic between sections.
 Sealant applied in factory according to manufacturers recommended method.

PIPE / WALL CONNECTIONS:
 100mm flexible watertight rubber seals integrally cast in concrete.

ACCESS OPENINGS:
 Tuf-Tite 610Ø Risers and Lids.
 Contact us for additional options

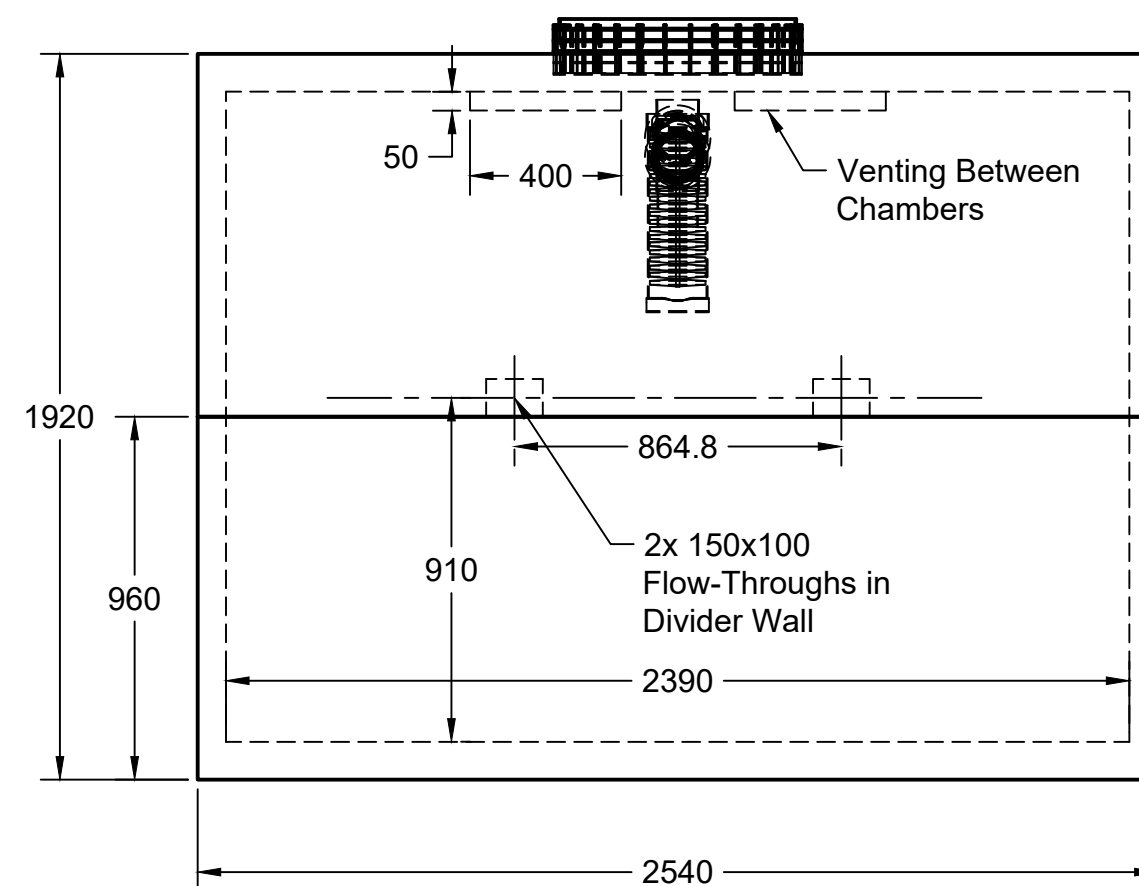
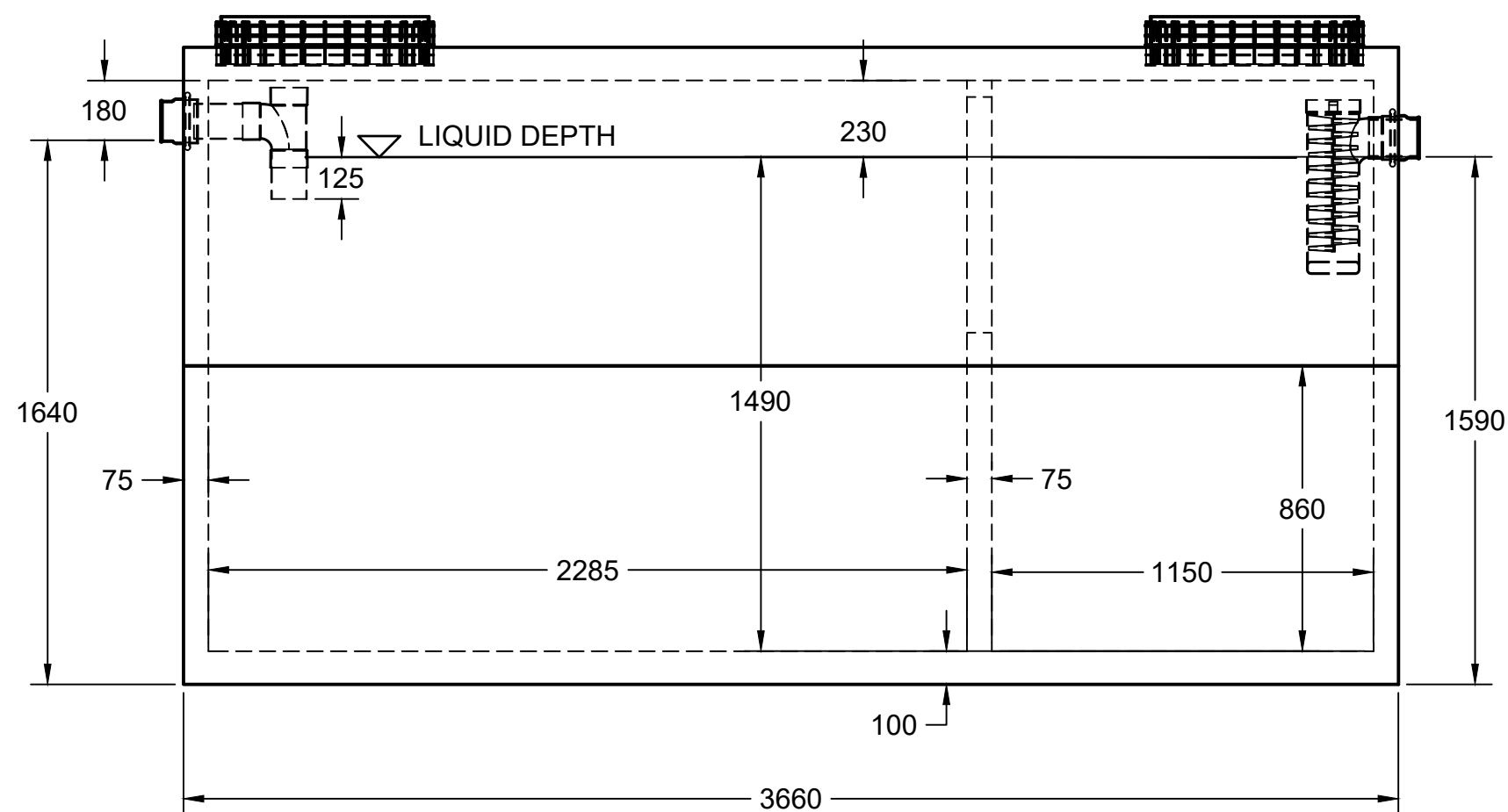

5450 Cuddy St Osgoode, ON K0A 2W0
 tel: (613) 826.2318 fax: (613) 826.3679
 toll free: 888.846.6664
 website: www.boydbrosconcrete.ca
 email: info@boydbrosconcrete.ca

PROJECT
Boyd Bros Form
 TITLE
12260 2-pc

DRAWN Rob Sanna 2/11/22 APPROVED		REV
SIZE C	DWG NAME 12260-2PC	2
SCALE 1:20	WEIGHT 9000kgs	SHEET 1/1

4

3

2

1

D

D

C

C

B

B

A

A